



## VISION Series

General Inserts for turning

# VM Breaker

**New**

### Features

- VM chip breaker ensures stable cutting performance even in high feed and deep depth of cut.
- Specially designed 3-dimensional chip breaker having low cutting resistance and improved rigidity of cutting.
- The best cutting performance is accomplished due to improved chip control on various workpiece under the continuous machining of high speed.



# VM Breaker

Features of VM C/B | Recommended Cutting Conditions

## Features of VM C/B

- The "convex part" for smooth chip breaking
- Excellent chip control in medium to roughing operations

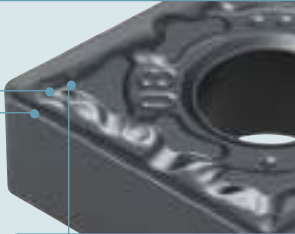

- Chip breaker with 2-step geometry
- Reduce chip control resistance at high speed & feed cutting due to smooth chip curling

- Rigid cutting edge
- Improved the rigidity of cutting edge and increased toughness guarantees long tool life under the heavy intermittent cutting

## Application of chip breaker

Work piece  
**P**  
Steel

Continuous

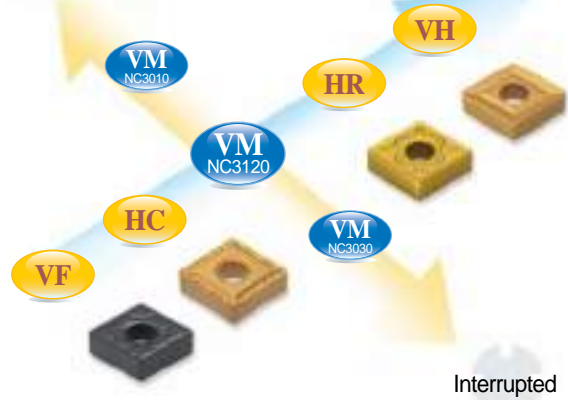

Interrupted

## Chip Control Range

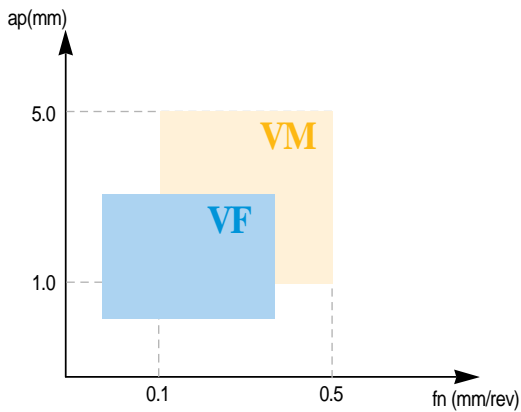

## Recommended Cutting Conditions

Workpiece	Hardness	Grade	vc (m/min)
<b>P</b> Soft Steels (SM10C~SM25C SS400, SCR415 SCM415. etc)	≤180HB	NC3010	310 (270~350)
		NC3120	290 (250~330)
		NC3030	270 (230~300)
General Steels (SM45C, SM55C, SCM430, SCM440. etc)	180~260HB	NC3010	220 (180~250)
		NC3120	200 (170~230)
		NC3030	190 (160~210)
Hardened Steels (SNC415, SNC815, SNCM240, SNCM439, STS12, STS61. etc)	260~350HB	NC3010	130 (100~150)
		NC3120	120 (90~140)
		NC3030	110 (80~130)

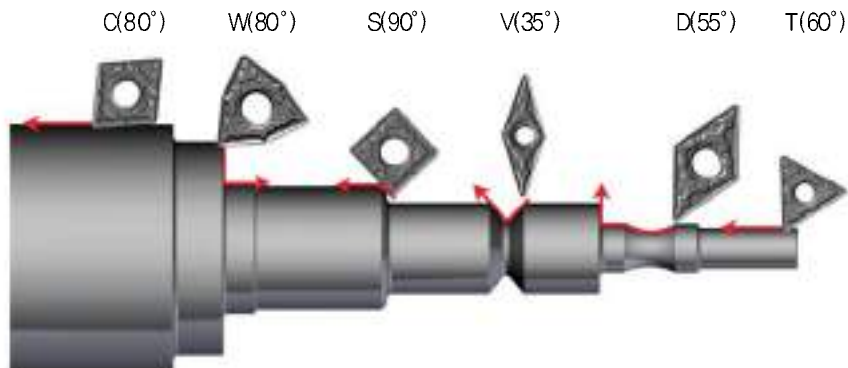

VM chip breaker tooling system



# VM Breaker

Wear resistance | Shock resistance | Application examples

## Wear resistance

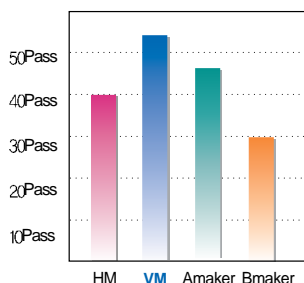

### Cutting Conditions

Designation : CNMG120408-VM  
 Grade : NC3120  
 Workpiece : SCM440  
 vc=250m/min  
 ap=2.0mm  
 fn=0.25~0.35mm/rev

## Shock resistance

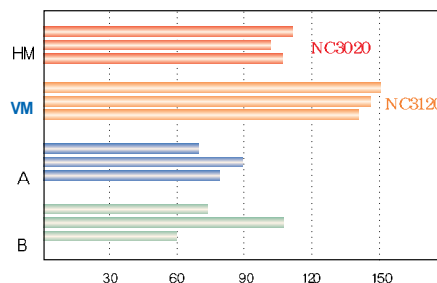



### Cutting Conditions

Designation : CNMG120408-VM  
 Grade : NC3120  
 Workpiece : SCM440(Interrupted)  
 vc=200 m/min  
 ap = 2.0mm  
 fn = 0.45mm/rev

## Application examples

Workpiece	Korloy		Competitor
 Hub (SM45C)	Designation	CNMG120408-VM (NC3010)	CNMG120408-O
	vc (m/min)	250	←
	fn (mm/rev)	0.35 ~ 0.4	←
	ap (mm)	1.5	←
	Machined part	Outer & Face	←
Result	120ea	100ea	

Workpiece	Korloy		Competitor
 Hub Wheel (SM45C)	Designation	CNMG120412-VM (NC3120)	CNMG120412-O
	vc (m/min)	300	←
	fn (mm/rev)	0.25	←
	ap (mm)	2.5	←
	Machined part	Outer & Face	←
Result	25ea	20ea	

Workpiece	Korloy		Competitor
 Ring (SCM440)	Designation	CNMG120408-VM (NC3120)	CNMG120408-O
	vc (m/min)	240	←
	fn (mm/rev)	0.2	←
	ap (mm)	2.0	←
	Machined part	Outer & Face	←
Result	200ea	100ea	

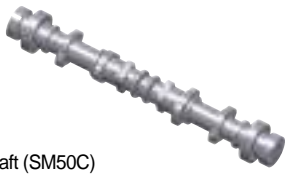
Workpiece	Korloy		Competitor
 Cam Shaft (SM50C)	Designation	DNMG15068-VM (NC3120)	DNMG15068-O
	vc (m/min)	157	←
	fn (mm/rev)	0.15 ~ 0.4	←
	ap (mm)	1.0 ~ 1.5	←
	Machined part	Outer & Face	←
Result	150ea	120ea	

Workpiece	Korloy		Competitor
 Pin Gear (SCM415)	Designation	TNMG160408-VM (NC3120)	TNMG160408-O
	vc (m/min)	336	←
	fn (mm/rev)	0.25	←
	ap (mm)	2.0	←
	Machined part	Outer & Face	←
Result	180ea	150ea	

# VM Breaker

VM-Insert

## VM-Insert

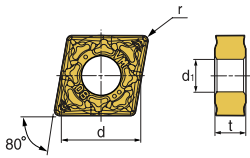
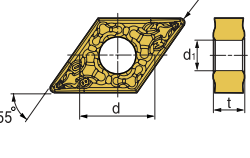
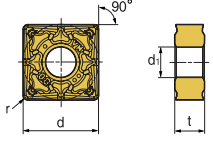
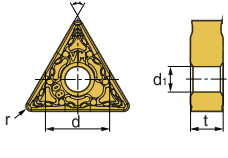
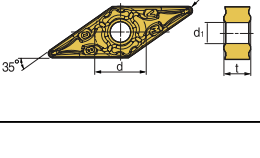
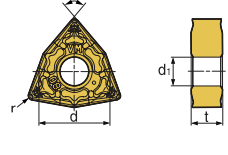
Geometry	Designation	CVD					PVD		CERMET
		NC3010	NC3120	NC3030	NC6110	NC9020	PC8010	PC9030	CN2000
	CNMG090304-VM	●	○	○					●
	CNMG090308-VM	●	○	○					●
	CNMG120404-VM	●	●	●	●			●	●
	CNMG120408-VM	●	●	●	●	●	●	●	●
	CNMG120412-VM	●	●	●	●		●		
	CNMG160608-VM	●	○	○					
	CNMG160612-VM		○	○					
	CNMG190608-VM	●	○	○					
	CNMG190612-VM	●	○	○					
	DNMG110404-VM								●
	DNMG110408-VM	○	○						●
	DNMG110412-VM	○	○						
	DNMG150404-VM	○	●	●	●	○			●
	DNMG150408-VM	○	●	●	●	○			●
	DNMG150412-VM								●
	DNMG150604-VM	○	●	●		○		●	●
	DNMG150608-VM	●	●	●		●		●	●
	DNMG150612-VM					○			●
	SNMG090304-VM	○	○						●
	SNMG090308-VM	○	○	●					●
	SNMG120404-VM	○	○	●	○				●
	SNMG120408-VM	●	●	●	●	●	●	●	●
	SNMG120412-VM	○	○	○	○				●
	SNMG190612-VM		○	○					
	TNMG110308-VM				○	○			
	TNMG160404-VM	●	●	●	●	○			●
	TNMG160408-VM	●	●		●			●	●
	TNMG160412-VM		●	●		○			●
	TNMG220404-VM					○			
	TNMG220408-VM		○						
	TNMG220412-VM		○						
	VNMG160404-VM	●	○						●
	VNMG160408-VM	●	●	●	●			●	●
	VNMG160412-VM								
	VNMG220404-VM								
	VNMG220408-VM								
	WNMG060404-VM		○						●
	WNMG060408-VM	○	○		○				●
	WNMG060412-VM		○						
	WNMG080404-VM	○	○						●
	WNMG080408-VM	●	●	●	●	●	●	●	●
	WNMG080412-VM		●	●	●				●

● Stock item, ○ Under preparing for stock



**HEAD OFFICE**  
 Holystar B/D 953-1, Doksanbon-Dong, Geumchun-Gu, Seoul, Korea  
 TEL: +82 2 522 3181 FAX: +82 2 522 3184, +82 2 3474 4744  
 WEB: www.korloy.com

**CHEONGJU FACTORY**  
 53-16, Songjeong-Dong, Hungduk-Gu, Cheongju, Chungcheongbuk-Do, Korea  
 TEL: +82 43 262 0141 FAX: +82 43 262 0146  
 E-MAIL: export@korloy.com

**JINCHEON FACTORY**  
 767-1, Gwanghyewon-Ri, Gwanghyewon-Myon, Jincheon-Gun, Chungcheongbuk-Do, Korea  
 TEL: +82 43 535 0141 FAX: +82 43 535 0144